

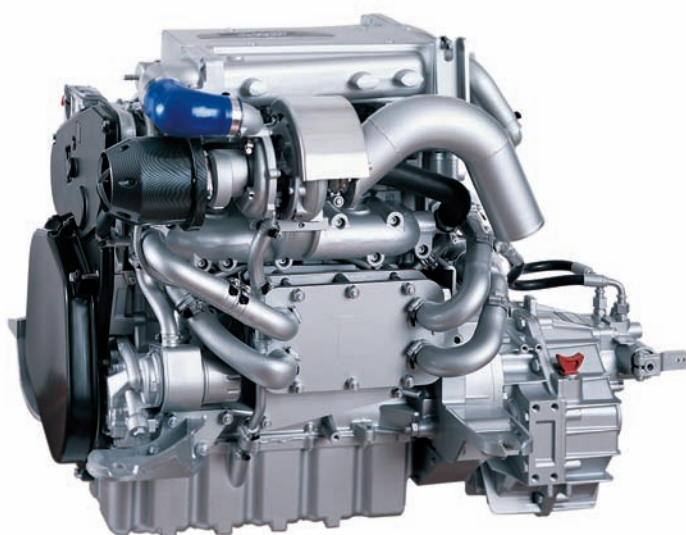

## MARINE DIESEL ENGINES



### FNM HPE 250

|                              |   |
|------------------------------|---|
| Configuration                | 4-stroke cycle, twin camshaft, 20 V                   |
| Maximum output at crankshaft | 184 kW/250 hp at 4200 rpm                             |
| Maximum output at propeller  | 177 kW/241 hp at 4200 rpm                             |
| Maximum torque               | 530 Nm at 2600 rpm                                    |
| Displacement                 | 2.387 c.c.  |
| Bore x stroke                | 82 x 90,4 mm  |
| Cylinders                    | 5, in-line  |
| Combustion system            | Direct injection Common Rail                          |
| Aspiration                   | Supercharged with variable geometry turbine           |
| Starting system              | Electric starting 12 V – 2,1 kW                       |
| Alternator                   | 12 V – 105 A  |
| Cooling system               | Double water cooling system with heat exchanger       |
| Lubrication system           | Totally enclosed, forced lubricating system with pump |
| Max. mounting inclination    | 14°   |
| Dry weight without gear      | 290 kg  |
| Environmental                | Meets the EU comprehensive emissions regulation 2006  |
| Engine mounting              | Rubber type anti-vibration mounting                   |

## Performance Curves (Output is according to ISO 8665)

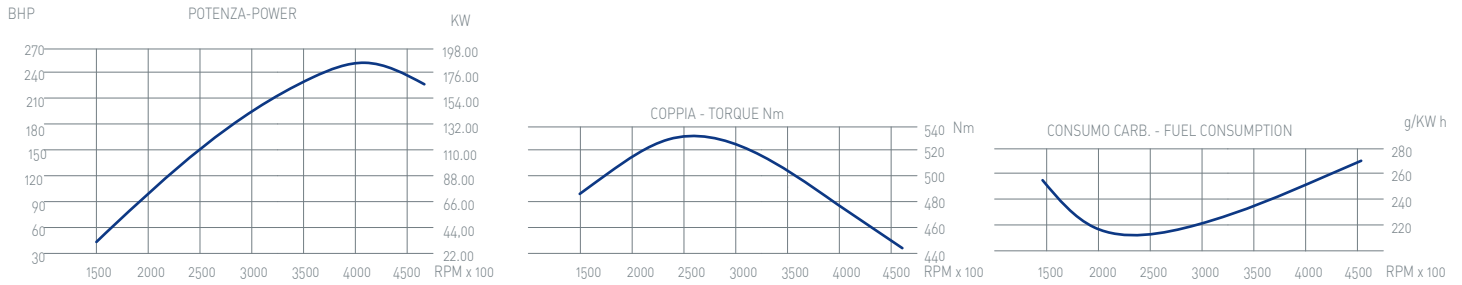

Dimensions (For detailed line-drawings, please refer to our website [www.fnm-marine.com](http://www.fnm-marine.com) or contact your supplier)

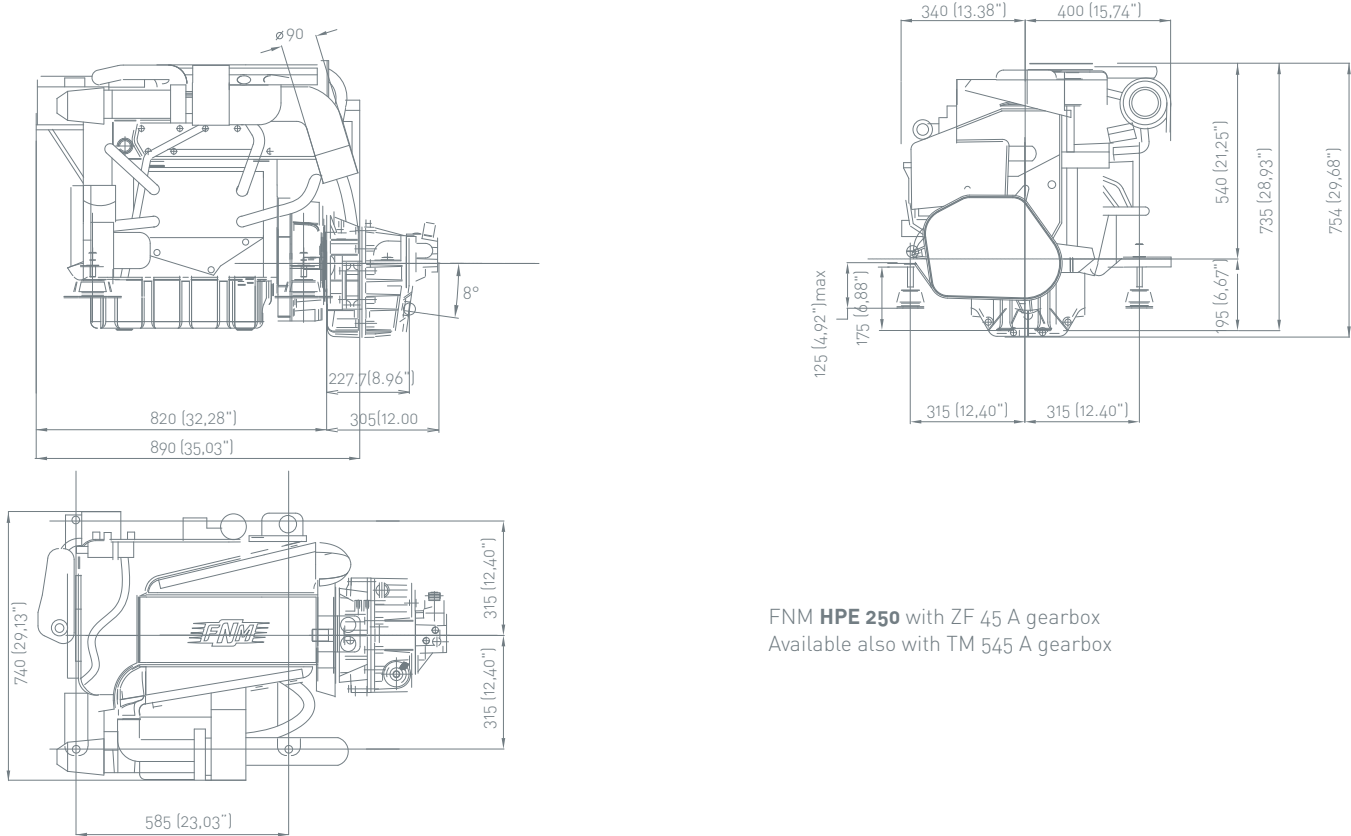

FNM HPE 250 with ZF 45 A gearbox  
Available also with TM 545 A gearbox

## Instrument Panel

- VDO Oil pressure
- VDO Water temperature
- VDO Voltmeter
- VDO Rpm counter
- 8 meter cable

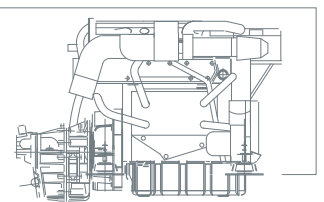

## Accessories

### Standard Package

- Gearbox
- Set of flexible mounts
- Alternator 12 V - 105 A with built-in regulator
- Starter motor 12 V - 2,1 kW
- Oil and fuel filters

- Stainless steel seawater-cooled elbow
- Racor filters
- Instrument panel with 8 mt. cable
- Bronze seawater pump
- Water-cooled exhaust manifold

### Optional

- Kit for boat internal heating
- 2 mt. auxiliary extension cable
- Flybridge instrument panel

- Kit for coupling to Mercruiser and Volvo stern drives
- Trolling valve
- 2-groove front pulley

Text and illustrations are not binding. CMD, owner of the FNM brand, reserves the right to introduce adaptations without prior notification.  
Compliant with the RCD 2003/44/CE and EPA emission standards.

