



MARINE DIESEL ENGINES



FNM HPE 80

| | |
|------------------------------|---|
| Configuration | 4-stroke cycle, twin camshaft, 16v |
| Maximum output at crankshaft | 59 kW/80 hp at 4000 rpm |
| Maximum torque | 157 Nm at 2200 rpm |
| Displacement | 1.248 c.c. |
| Bore x stroke | 69,6 x 82 mm |
| Cylinders | 4, in line |
| Combustion system | Direct injection Common Rail |
| Aspiration | Turbocharged |
| Starting system | Electric starting 12 V – 1,3 kW |
| Alternator | 14 V – 75 A |
| Cooling system | Double water cooling system with heat exchanger |
| Lubrication system | Totally enclosed, forced lubricating system with pump |
| Max. mounting inclination | 10° |
| Dry weight without gear | 160 kg |
| Environmental | Meets the EU comprehensive emissions regulation 2006 |
| Engine mounting | Rubber type anti-vibration mounting |

Performance Curves (Output is according to ISO 8665)

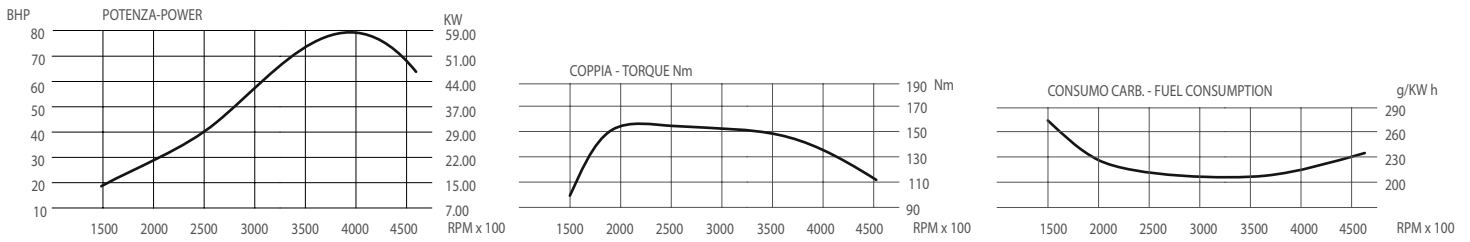

Dimensions (For detailed line-drawings, please refer to our website www.fnm-marine.com or contact your supplier)

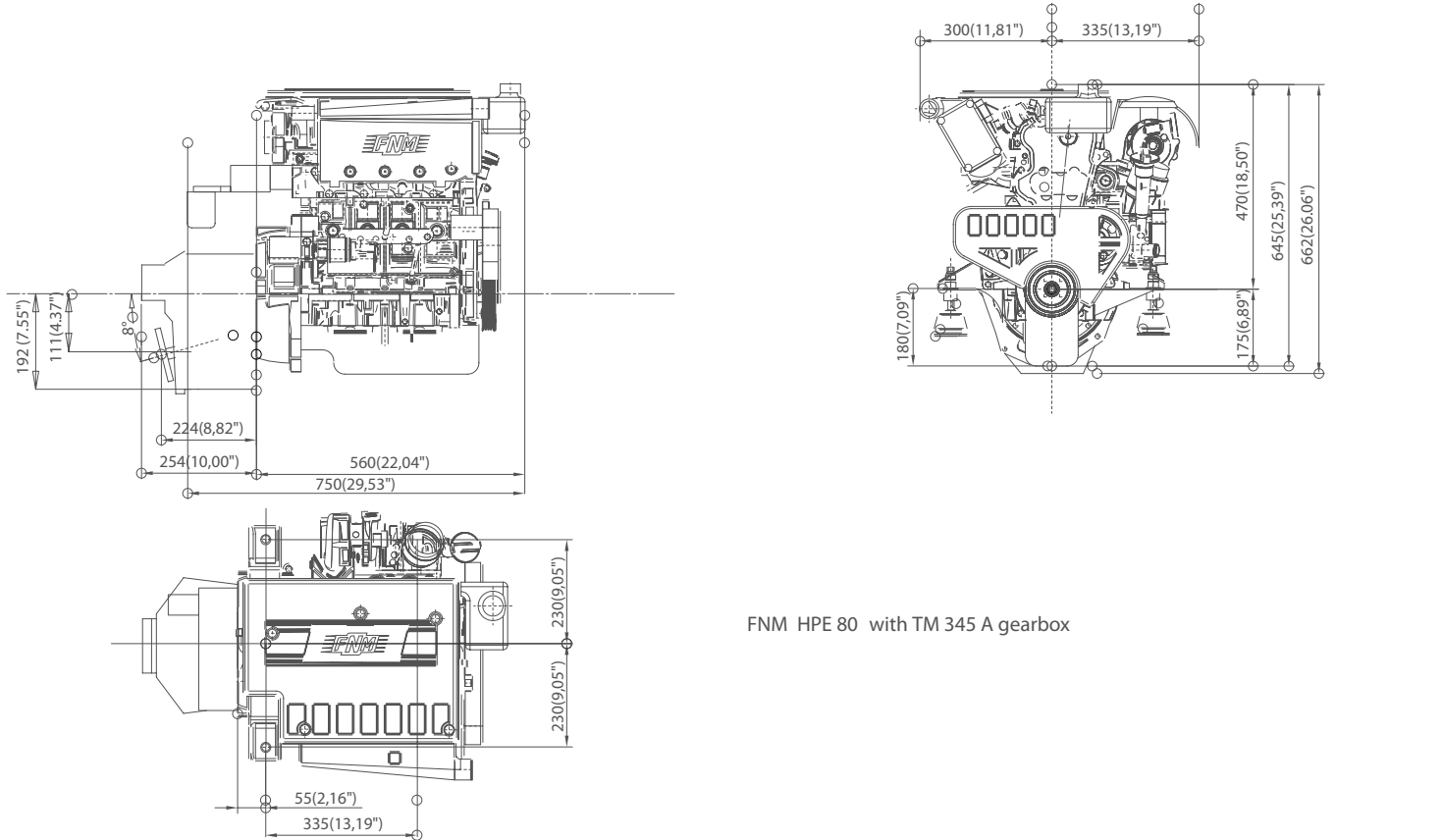

Instrument Panel

- VDO Oil pressure
- VDO Water temperature
- VDO Voltmeter
- VDO Rpm counter
- 8 meter cable

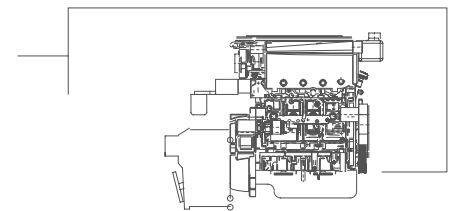

Accessories

Standard Package

- Gearbox
- Set of flexible mounts
- Alternator 14 V – 75 A with built-in regulator
- Starter motor 12 V – 1,3 kW
- Oil and fuel filters

- Stainless steel seawater-cooled elbow
- Racor filters
- Instrument panel with 8 mt. cable
- Bronze seawater pump
- Engine top cover
- Water-cooled exhaust manifold

Optional

- Kit for boat internal heating
- 2 mt. auxiliary extension cable
- Flybridge instrument panel

- Trolling valve
- 2-groove front pulley

Text and illustrations are not binding. CMD, owner of the FNM brand, reserves the right to introduce adaptations without prior notification. Compliant with the RCD 2003/44/CE and EPA emission standards.

